

**EC DECLARATION OF CONFORMITY**

We declare under our sole responsibility that this product is in conformity with standards or standardized documents EN60745, EN55014 and EN61000-3 in accordance with Council Directives 73/23/EEC, 89/336/EEC and 98/37/EC.

Manufactured for

**KENNEDY TOOLS**  
Wigston Works, Leicester, England.  
ISO 9002 REGISTERED COMPANY

CE

Signed: *Martin Cooke*

Date: 31 January 2007

Name: Martin Cooke

Position: Director, The Kennedy Group Ltd.

**QUALITY GUARANTEE & WARRANTY**

K-EIKO INDUSTRIAL POWER TOOLS carry one years manufacturers warranty.

K-EIKO INDUSTRIAL POWER TOOLS are designed & manufactured to the highest standards & specifications

Assuring the quality and performance required by all sectors of industry.

K-EIKO INDUSTRIAL POWER TOOLS are fully guaranteed against faulty materials & workmanship

Should they be found to be defective, they will either be repaired or replaced free of charge (fair wear and tear and/or misuse excepted).

Please retain supplier invoice as proof of purchase.

Manufactured For:  
**KENNEDY TOOLS**  
Wigston Works, Leicester, England.  
ISO 9001 REGISTERED COMPANY

**AVAILABLE FROM YOUR DISTRIBUTOR**



**INDUSTRIAL POWER TOOLS**

**Jig Saw**

**MODEL EJS120PV**

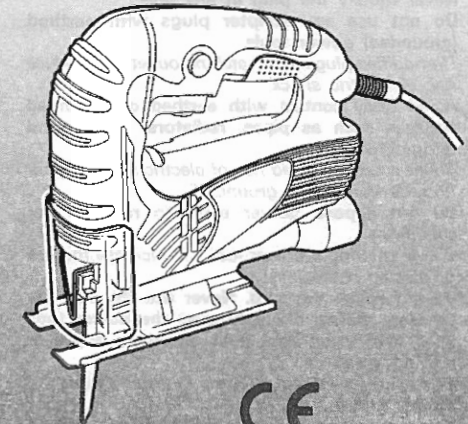

- Nonskid large soft grip handle
- Easy-to-operate large trigger switch (equipped with speed control dial)
- Powerful dust blowing allows a clear view of the ink line
- Compact and lightweight

CE



**WARNING:** THE SAFETY INFORMATION GIVEN INSIDE MUST BE READ AND UNDERSTOOD BY ANY PERSON USING, INSTALLING, REPAIRING OR MAINTAINING THESE TOOLS.

**OPERATOR'S MANUAL**

Please retain this information for future reference

701

Code No. C99160611  
Printed in China

## GENERAL SAFETY RULES

### WARNING!

#### Read all instructions

Failure to follow all instructions listed below may result in electric shock, fire and/or serious injury.

The term "power tool" in all of the warnings listed below refers to your mains operated (corded) power tool or battery operated (cordless) power tool.

### SAVE THESE INSTRUCTIONS

#### 1) Work area

- a) **Keep work area clean and well lit.**  
*Cluttered and dark areas invite accidents.*
- b) **Do not operate power tools in explosive atmospheres, such as in the presence of flammable liquids, gases or dust.**  
*Power tools create sparks which may ignite the dust of fumes.*
- c) **Keep children and bystanders away while operating a power tool.**  
*Distractions can cause you to lose control.*

#### 2) Electrical safety

- a) **Power tool plugs must match the outlet. Never modify the plug in any way.**  
**Do not use any adapter plugs with earthed (grounded) power tools.**  
*Unmodified plugs and matching outlets will reduce risk of electric shock.*
- b) **Avoid body contact with earthed or grounded surfaces such as pipes, radiators, ranges and refrigerators.**  
*There is an increased risk of electric shock if your body is earthed or grounded.*
- c) **Do not expose power tools to rain or wet conditions.**  
*Water entering a power tool will increase the risk of electric shock.*
- d) **Do not abuse the cord. Never use the cord for carrying, pulling or unplugging the power tool. Keep cord away from heat, oil, sharp edges or moving parts.**  
*Damaged or entangled cords increase the risk of electric shock.*
- e) **When operating a power tool outdoors, use an extension cord suitable for outdoor use.**  
*Use of a cord suitable for outdoor use reduces the risk of electric shock.*

#### 3) Personal safety

- a) **Stay alert, watch what you are doing and use common sense when operating a power tool. Do not use a power tool while you are tired or under the influence of drugs, alcohol or medication.**  
*A moment of inattention while operating power tools may result in serious personal injury.*
- b) **Use safety equipment. Always wear eye protection.**  
*Safety equipment such as dust mask, non-skid safety shoes, hard hat, or hearing protection used for appropriate conditions will reduce personal injuries.*
- c) **Avoid accidental starting. Ensure the switch is in the off position before plugging in.**  
*Carrying power tools with your finger on the switch or plugging in power tools that have the switch on invites accidents.*

- d) **Remove any adjusting key or wrench before turning the power tool on.**

*A wrench or a key left attached to a rotating part of the power tool may result in personal injury.*

- e) **Do not overreach. Keep proper footing and balance at all times.**  
*This enables better control of the power tool in unexpected situations.*
- f) **Dress properly. Do not wear loose clothing or jewellery. Keep your hair, clothing and gloves away from moving parts.**  
*Loose clothes, jewellery or long hair can be caught in moving parts.*
- g) **If devices are provided for the connection of dust extraction and collection facilities, ensure these are connected and properly used.**  
*Use of these devices can reduce dust related hazards.*

#### 4) Power tool use and care

- a) **Do not force the power tool. Use the correct power tool for your application.**  
*The correct power tool will do the job better and safer at the rate for which it was designed.*
- b) **Do not use the power tool if the switch does not turn it on and off.**  
*Any power tool that cannot be controlled with the switch is dangerous and must be repaired.*
- c) **Disconnect the plug from the power source before making any adjustments, changing accessories, or storing power tools.**  
*Such preventive safety measures reduce the risk of starting the power tool accidentally.*
- d) **Store idle power tools out of the reach of children and do not allow persons unfamiliar with the power tool or these instructions to operate the power tool.**  
*Power tools are dangerous in the hands of untrained users.*
- e) **Maintain power tools. Check for misalignment or binding of moving parts, breakage of parts and any other condition that may affect the power tools operation.**  
**If damaged, have the power tool repaired before use.**  
*Many accidents are caused by poorly maintained power tools.*
- f) **Keep cutting tools sharp and clean.**  
*Properly maintained cutting tools with sharp cutting edges are less likely to bind and are easier to control.*
- g) **Use the power tool, accessories and tool bits etc., in accordance with these instructions and in the manner intended for the particular type of power tool, taking into account the working conditions and the work to be performed.**  
*Use of the power tool for operations different from intended could result in a hazardous situation.*

#### 5) Service

- a) **Have your power tool serviced by a qualified repair person using only identical replacement parts.**  
*This will ensure that the safety of the power tool is maintained.*

### PRECAUTION

**Keep children and infirm persons away.**

**When not in use, tools should be stored out of reach of children and infirm persons.**

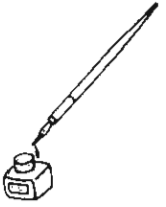



## SPECIFICATIONS

Voltage (by areas)*	(110V, 115V, 120V, 127V, 220V, 230V, 240V) $\sim$
Power input	400W*
Max. cutting depth	Wood: 65mm Mild steel: 6mm
No-load speed	0 – 3000 min <sup>-1</sup>
Stroke	18mm
Min. cutting radius	25mm
Weight (without cord)	1.5kg

\* Be sure to check the nameplate on product as it is subject to change by areas.

## STANDARD ACCESSORIES

- (1) Blade No.31 ..... 1  
For cutting thick lumber
  - (2) Splinter guard ..... 1
  - (3) Chip cover ..... 1
  - (4) Hexagonal bar wrench ..... 1
- Standard accessories are subject to change without notice.

## OPTIONAL ACCESSORIES (sold separately)

- (1) Blades, No.1 – No.6, 31\*  
\* No.31 Blade is a standard accessory.
  - (2) Guide
- Optional accessories are subject to change without notice.

## APPLICATIONS

- Cutting various lumber and pocket cutting
- Cutting mild steel plate, aluminum plate, and copper plate
- Cutting synthetic resins, such as phenol resin and vinyl chloride
- Cutting thin and soft construction materials

## PRIOR TO OPERATION

- 1. Power source**  
Ensure that the power source to be utilized conforms to the power requirements specified on the product nameplate.
- 2. Power switch**  
Ensure that the power switch is in the OFF position. If the plug is connected to a receptacle while the power switch is in the ON position, the power tool will start operating immediately, which could cause a serious accident.
- 3. Extension cord**  
When the work area is removed from the power source, use an extension cord of sufficient thickness and rated capacity. The extension cord should be kept as short as practicable.

## MOUNTING THE BLADE

1. Use the accessory hexagonal bar wrench to loosen the blade set screws on the blade holder, as shown in Fig. 1(a).

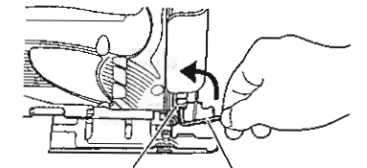

Blade set screw      Hexagonal bar wrench

Fig. 1(a)

2. Holding the blade with its cutting edge facing the front, insert the mounting portion of the blade into the plunger groove until it touches the bottom of the groove.
3. As shown in Fig. 1(b), firmly clamp the side screw.

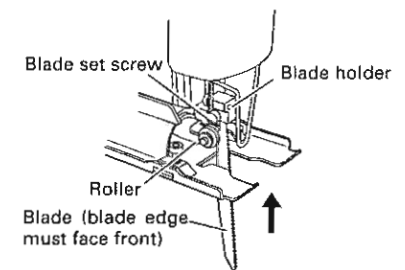
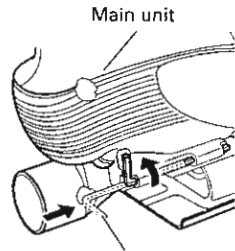

Fig. 1(b)

## CAUTION

- Loosened set screws may cause the blade to be damaged. Always ensure that the set screws are securely tightened. Always ensure that the plunger groove is clean and clear of sawdust to ensure proper blade mounting and set screw clamping.
4. Storing the hexagonal bar wrench
    - (1) Insert in a hole on the side of the main unit with holding the short side horizontally as shown in Fig. 2.

- (2) Rotate with the hexagonal bar wrench inserted and secure as shown in Fig. 2.



Hexagonal bar wrench

Fig. 2

### ADJUSTING THE GUIDE ROLLER

The guide roller, shown in Fig. 3, is employed to prevent the blade from snapping. Prior to use, adjust guide roller in accordance with the following procedures:

- (1) Loosen the holder set screw with the accessory hexagonal bar wrench.
  - (2) Gently slide the guide roller until the roller groove lightly touches the back of the blade.
- NOTE**  
On delivery from the factory, there is a gap of about 3mm between the roller and blade.
- (3) Firmly tighten the holder set screw.

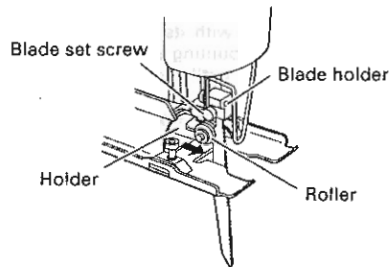

Fig. 3

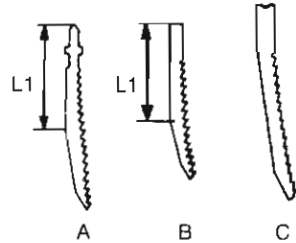

Fig. 4

### CHIP COVER POSITIONING

#### 1. Chip cover

Use the chip cover to reduce flying of cut particles and to easily operate the saw.

Slide the chip cover while lightly pressing its front section.

The chip cover can be set at three positions as shown in Fig. 5.

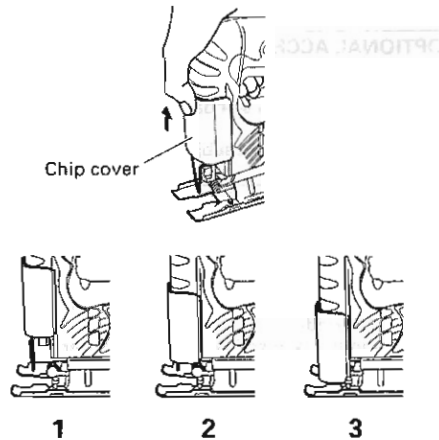

Fig. 5

#### 2. How to choose the position of the ship cover

Set the chip cover to the first step when attaching or removing the blade.

Set the chip cover to the second step when cutting wooden materials.

Set the chip cover to the second or third step when cutting metal materials such as steel.

#### CAUTION

- Keep always the chip cover in the low position when operating the tool.
- Wear protection glasses even if the chip cover is used.

Item No.	Part Name
1	CHIP COVER
2	GUARD BAR
3	LABEL
4	HOUSING (A), (B) SET
5	SWITCH
6	NOISE SUPPRESSOR
7	TAPPING SCREW (W/FLANGE) D4x20
8	NAME PLATE
9	CORD CLIP
10	TAPPING SCREW (W/FLANGE) D4x16
11	BASE
12	HEX. SOCKET HD. BOLT M4x8
13	PLATE NUT
14	CARBON BRUSH
15	BRUSH HOLDER
16	CORD ARMOR
17	ROLLER HOLDER
18	HEX. SOCKET HD. BOLT M4x16
19	CORO
20	PLUNGER HOLDER
21	PLUNGER
22	CONNECTING PIECE
23	GEAR
24	WASHER
25	HOLDER
26	BALL BEARING 608VVMC2EP52L
27	ARMATURE
28	BALL BEARING 628VVMC2EP52S
29	STATOR
30	TERMINAL
501	HEX. BAR WRENCH 3MM
502	SPLINTER GUARD

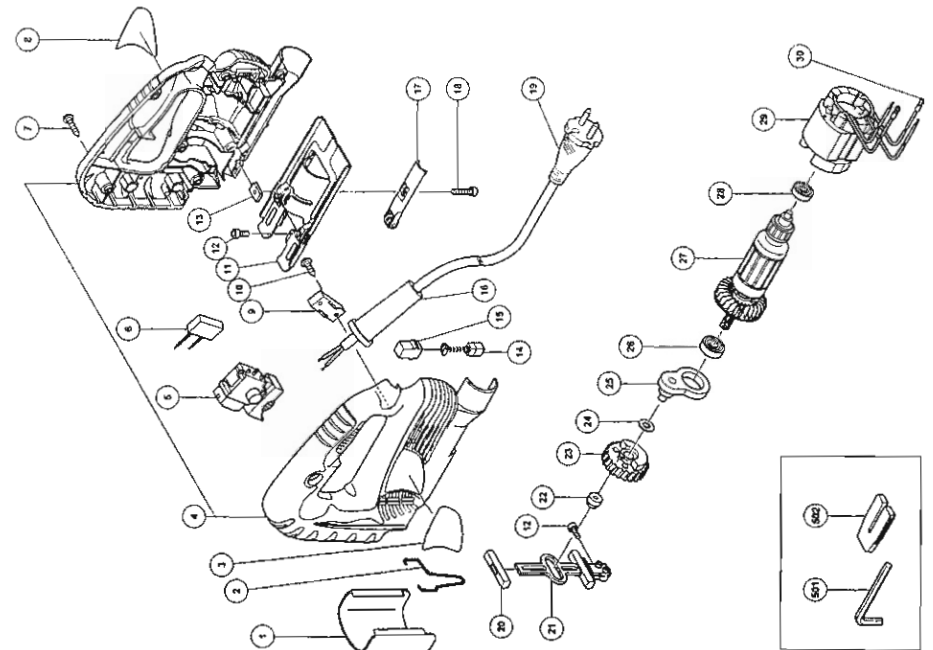

## IMPORTANT

Correct connection of the plug

The wires of the main lead are coloured in accordance with the following code:

Blue : -Neutral

Brown : -Live

As the colours of the wires in the main lead of this tool may not correspond with the coloured markings identifying the terminals in your plug proceed as follows: The wire coloured blue must be connected to the terminal marked with the letter N or coloured black. The wire coloured brown must be connected to the terminal marked with the letter L or coloured red. Neither core must be connected to the earth terminal.

## NOTE

This requirement is provided according to BRITISH STANDARD 2769: 1984

Therefore, the letter code and colour code may not be applicable to other markets except The United Kingdom.

## Information concerning airborne noise and vibration

The measured values were determined according to EN60745 and declared in accordance with ISO 4871.

Measured A-weighted sound power level: 95 dB (A).

Measured A-weighted sound pressure level: 84 dB (A).

Uncertainty KpA: 3 dB (A).

Wear ear protection.

The typical weighted root mean square acceleration value: 10.2 m/s<sup>2</sup>.



Only for EU countries

Do not dispose of electric tools together with household waste material!

In observance of European Directive 2002/96/EC on waste electrical and electronic equipment and its implementation in accordance with national law, electric tools that have reached the end of their life must be collected separately and returned to an environmentally compatible recycling facility.

## ADJUSTING THE BLADE OPERATING SPEED

The blade operating speed can be adjusted within a range of 0 to 3000 min<sup>-1</sup> according to the degree that the trigger switch is depressed. Select the speed appropriate to the material being worked and/or the working conditions.

To achieve continuous operation, pull the trigger switch all the way back and depress the stopper. Then, turn the speed adjustment knob to adjust the blade operating speed as desired.

## NOTE

The speed adjustment knob rotates approximately 1.5 turns. To turn the switch OFF, pull the trigger switch again to disengage the stopper, and release the trigger switch.

## CUTTING

### CAUTION

- While sawing, the base must be firmly in contact with the material surface, and the blade must be held at a right angle. If the base becomes separated from the material, it could cause the blade to break.
- When cutting while holding the front surface, be careful of the moving blade and hold the upper part firmly.

### 1. Rectilinear cutting

- (1) To ensure accurate rectilinear cutting, employ the optional accessory guide as shown in Fig. 6.

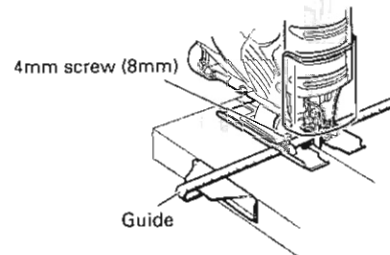

Fig. 6

- (2) Use the splinter guard to reduce roughness of the cutting surface of wooden materials. Attach the splinter guard by inserting it from the front section of the base until it clicks into place. (Fig. 7)

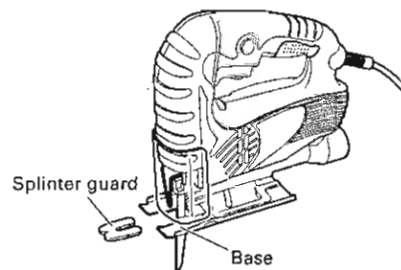

Fig. 7

### CAUTION

Set the base in the front position when using the splinter guard.

### 2. Cutting a circle or a circular arc

To ensure efficient cutting, employ the optional accessory guide and nail or wood screw as shown in Fig. 8.

When mounting the guide, loosen the base bottom screw, and shift the base as far forward as it will go.

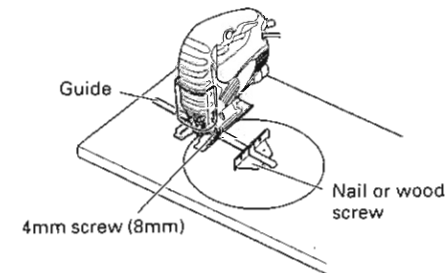

Fig. 8

### 3. Sawing curved lines

When sawing a small circular arc, reduce the feeding speed of the machine. If the machine is fed too fast, it could cause the blade to break.

### 4. Cutting metallic materials

Always use an appropriate cutting agent (spindle oil, soapy water, etc.). When a liquid cutting agent is not available, apply grease to the back surface of the material to be cut.

### 5. Pocket cutting

- (1) In lumber

Aligning the blade direction with the grain of the wood, cut step by step until a window hole is cut in the center of the lumber. (Fig. 9)

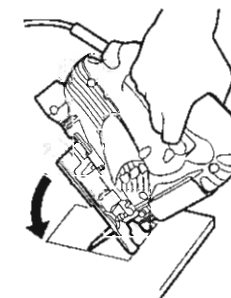

Fig. 9

- (2) In other materials

When cutting a window hole in materials other than lumber, initially bore a hole with a drill or similar tool from which to start cutting.

## 6. Angular cutting

Set the chip cover to the first step. (Fig. 5)

To adjust the angle of inclination; loosen the base bottom screw, shift the base position to the side groove of the semicircular portion, align the scale on the base semicircular portion (figures engraved on the scale indicate the angle of inclination) with the housing edge line, and thoroughly tighten the base bottom screw. (Fig. 10 and 11)

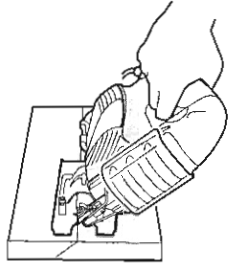

Fig. 10

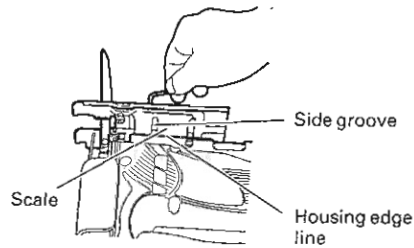

Fig. 11

### CAUTION

Set the screw to the opposite side of the inclining side when using the guide. (Fig. 12)

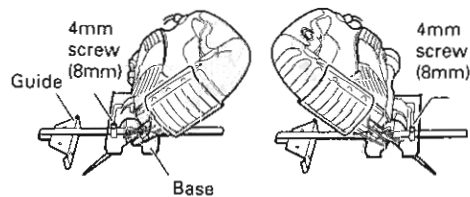

Fig. 12

## 7. Dust produced in operation

### CAUTION

- To prevent accidents, turn the switch off and remove the plug from the power supply when not in use.
- For instruction on using the dust collector and applicable cutting debris, please read the dust collector instruction manual.

*The dust produced in normal operation may affect the operator's health. Either of following way is recommended.*

- a) Wear a dust mask
- b) Use external dust collection equipment

When using the external dust collection equipment, connect the rubber adapter (accessory of external dust collection equipment) with end of hose from external dust collection equipment.

Then connect the another end of rubber adapter with the hose attachment part that positioned in rear end of jig saw. (See Fig. 13)

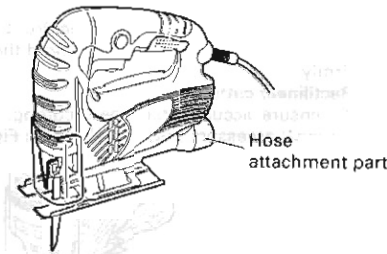

Fig. 13

## SELECTION OF BLADES

### 1. Accessory blades

To ensure maximum operating efficiency and results it is very important to select the appropriate blade best suited to the type and thickness of the material to be cut. One type of blade is provided as standard accessory. The blade number is engraved in the vicinity of the mounting portion of each blade. Select appropriate blades by referring to Table 1.

Table 1 List of Appropriate Blades

Material to be cut	Material quality	Blade No.
Lumber	General lumber	No.1 or No.31 (thick plate) or No.41 (thick plate) or No.2 (thin plate)
	Plywood	No.3 or No.6
Iron plate	Mild steel plate	No.6
Nonferrous metal	Aluminum, copper, brass	No.6
Synthetic resin	Phenol resin, melamine resin, etc.	No.4 (thick plate) or No.6 (thin plate)
	Vinyl chloride, acryl resin, etc.	No.2 or No.4 (thick plate) or No.6 (thin plate)
Pulp	Foamed styrol, etc.	No.2
	Cardboard, corrugated paper	No.2
	Hardboard	No.5 or No.6
Others	Fiberboard	No.6
	Hard rubber	No.2
	Slate	No.5

### 2. Acceptable commercial blades (Fig. 14)

This machine is designed to accept most blades available on the open market. As illustrated in Fig. 14, blade dimension restrictions are as follows:

- Thickness : L2 ..... Less than 1.6mm
- Width : L3 ..... 6.3mm
- L4 ..... 8mm
- L5 ..... 7mm

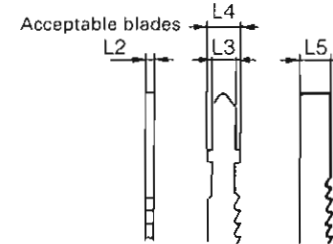

Fig. 14

### NOTE

When cutting thick materials, use K-EIKO genuine blades which have an inclination as shown in Fig. 4-A or B.

## MAINTENANCE AND INSPECTION

### 1. Inspecting the blade

Continued use of a dull or damaged blade will result in reduced cutting efficiency and may cause overloading of the motor. Replace the blade with a new one as soon as excessive abrasion is noted.

### 2. Inspecting the mounting screws

Regularly inspect all mounting screws and ensure that they are properly tightened. Should any of the screws be loose, retighten them immediately. Failure to do so could result in serious hazard.

### 3. Maintenance of the motor

The motor unit winding is the very "heart" of the power tool. Exercise due care to ensure the winding does not become damaged and/or wet with oil or water.

### 4. Replacing supply cord

If the supply cord of Tool is damaged, the Tool must be returned to K-EIKO Authorized Service Center for the cord to be replaced.

### 5. Servicing

Consult an authorized Service Agent in the event of power tool failure.

### 6. Service parts list

#### CAUTION

Repair, modification and inspection of K-EIKO Power Tools must be carried out by an K-EIKO Authorized Service Center.

This Parts List will be helpful if presented with the tool to the K-EIKO Authorized Service Center when requesting repair or other maintenance.

In the operation and maintenance of power tools, the safety regulations and standards prescribed in each country must be observed.

#### MODIFICATIONS

K-EIKO Power Tools are constantly being improved and modified to incorporate the latest technological advancements.

Accordingly, some parts may be changed without prior notice.

#### NOTE

Due to K-EIKO's continuing program of research and development, the specifications herein are subject to change without prior notice.