



SELF-GRIP



Double-Ended Blades (F-Type)

Parting and Grooving

Tool blocks available separately details available on request.

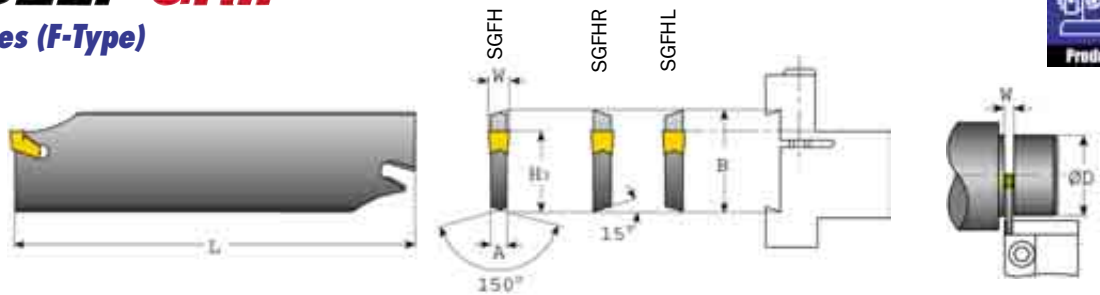

SGFH/R/L

B	W Range	Designation	A	L	H ₃	D Max	D Min	Inserts	Extractor	Order Code ISC-134	Offer Price/1
19	1.2	SGFH 19-1.2	0.93 ⁽¹⁾	86	15.7	18	-	GF: 1.2	ESG-05	-4802C	£49.16
	1.6	SGFH 19-1	1.2 ⁽¹⁾			32	-	GF: 1.6	ESG-05	-4801B	£49.16
	1.80-2.69	SGFH 19-2	1.6			38	-	GF: 2;2.4	ESG-1	-4803D	£49.16
26	1.2	SGFH 26-1.2	0.93 ⁽¹⁾	110	21.4	20	-	GF: 1.2	ESG-05	-4806G	£54.58
	1.6	SGFH 26-1	1.2 ⁽¹⁾			35	-	GF: 1.6	ESG-05	-4805F	£54.58
	1.80-2.69	SGFH 26-2	1.6			50	-	GF: 2;2.4	ESG-1	-4807H	£54.58
	2.70-3.53	SGFH 26-3	2.4			75	-	GF: 3	ESG-1	-4809K	£54.58
	2.70-3.53	SGFH 26K-3	2.4			52	15	GF: 3	ESG-1	-4810R	£68.29
	3.54-4.52	SGFH 26-4	3.2			80	-	GF: 4	ESG-1	-4811M	£54.58
4.54-4.52	SGFH 26-5	4.0	80	-	GF: 4.8;5	ESG-1	-4813P	£54.58			
32	1.6	SGFH 32-1	1.2 ⁽²⁾	150	24.8	38	-	GF: 1.6	ESG-05	-4815R	£60.06
	1.80-2.69	SGFH 32-2	1.6 ⁽²⁾			50	-	GF: 2;2.4	ESG-1	-4817T	£60.06
	2.70-3.53	SGFH 32-3	2.4			100	-	GF: 3	ESG-1	-4819W	£60.06
	3.54-4.52	SGFH 32-4	3.2			100	-	GF: 4	ESG-1	-4823C	£60.06
	4.54-5.50	SGFH 32-5	4.0			120	-	GF: 4.8;5	ESG-1	-4825E	£60.06
	5.51-6.50	SGFH 32-6	5.2			120	-	GF: 6	ESG-1	-4827G	£60.06
45	3.0	SGFH 45-3	2.4	225	38	160	-	GF: 3	ESG-1	-4830C	£99.36
	4.1	SGFH 45-4	3.2			160	-	GF: 4	ESG-1	-4830G	£99.36
	4.8 & 5	SGFH 45-5	4.0			160	-	GF: 4.8 & 5	ESG-1	-4830H	£99.36
	6.4	SGFH 45-6	5.2			160	-	GF: 6	ESG-1	-4830J	£99.36
52.6	8.0	SGFH 52-8	6.8	190	45.0	190	-	GF: 8	ESG-9	-4831G	£90.46
	8.0	SGFH 53-8	6.8			220	-	GF: 8	ESG-9	-4833N	£103.07
	9.5	SGFH 52-9	8.0			200	-	GF: 9	ESG-9	-4832H	£90.46
	9.5	SGFH 53-9	8.0			250	-	GF: 9	ESG-9	-4835R	£103.07
	12.7	SGFHR 53-12	11.1			250	-	GF: 12	ESG-9	-4866T	£126.80
	12.7	SGFHL 53-12	11.1			250	-	GF: 12	ESG-9	-4854F	£126.80

⁽¹⁾ A = 0.93 or 1.2 at DOC area only. Overall thickness is 1.6mm.
⁽²⁾ A = 1.2 or 1.6 at DOC area only. Overall thickness is 2.4mm.

"B" dimension links blades and blocks.

Blocks for Blades

Parting and Grooving

Blades type SGB are shown below.

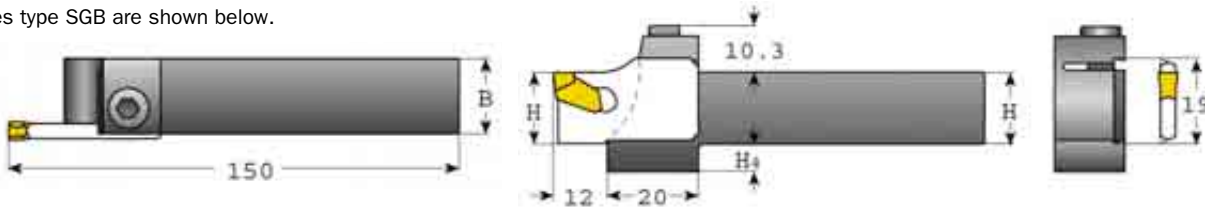

Right-hand shown

SGBHR/L

H	Designation	B	H ₄	Screw	Blade	Order Code ISC-134		Offer Price/1
						R/Hand	L/Hand	
10	SGBHR/L 1010	10	10	SR M5 x 25	SGB 19...	-4306G	-4300A	£54.43
12	SGBHR/L 1212	12	8	SR M5 x 25		-4307H	-4301B	£54.43
14	SGBHR/L 1414	14	6	SR M5 x 25		-4308J	-4302C	£54.43
16	SGBHR/L 1616	16	6	SR M5 x 25		-4309K	-4303D	£57.17
20	SGBHR/L 2020	20	2	SR M5 x 25		-4310L	-4304E	£59.99
25	SGBHR/L 2525	25	0	SR M5 x 25		-4311M	-4305F	£62.95

Hex key HW-4 supplied with each block.

Blades F-Type

Parting and Grooving

To fit blocks type SGBHR/L shown above.

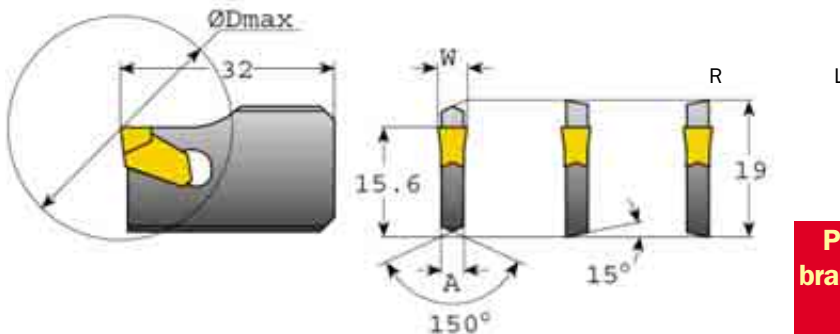

Please contact your local branch for quantity discounts and contract prices

SGB

W Range	D Max	Designation	A	Inserts	Extractor	Order Code ISC-134	Offer Price/1
1.2	18	SGB 19-1.2	0.93 ⁽¹⁾	GF: 1.2	ESG-05	-4288Z	£24.73
1.6	36	SGB 19-1.6	1.2 ⁽¹⁾	GF: 1.6	ESG-1	-4290A	£24.73
1.80 - 2.69	36	SGB 19-2	1.6	GF: 2;2.4	ESG-1	-4292C	£24.73
2.70 - 3.53	36	SGB 19-3	2.4	GF: 3	ESG-1	-4294E	£24.73

⁽¹⁾ A = At DOC area only. Overall thickness is 1.6mm.